

### Input data

System of measurement		Metric
Input type		Coupling for electric motor
Input speed	[rpm]	1400
Output speed	[rpm]	93.33
Ratio (i=)		15
Frequency	[Hz]	50
Input options		IEC
Requested input power	[kW]	0.13
Service factor		7.1
Rated Power P1	[kW]	0.93

### Output data

<b>Gear unit</b>	<b>F RS 50 Output flange No Flange FL (bolted) 15 63 B14 AC 25 B3</b>
------------------	---

Type		RS - Worm speed reducers
Input type		F (Elastic coupling)
Size		50
Ratio (i=)		15
Input flange		B14
Mounting position		B3
Input speed	[rpm]	1400
Output speed	[rpm]	93.33
Rated output torque	[Nm]	10.38
Service Factor		7.1
Efficiency		0.78
Inertia moment	[kgm <sup>2</sup> ]	0.00005

#### Gear unit configuration

Output shaft	Hollow output shaft
Fixing	Output flange
Right side flange	No Flange
Left side flange	FL (bolted)

#### Output radial and axial loads

Ball bearings output radial load	[N]	1700
Taper bearings output radial load	[N]	2400
Ball bearings output axial load	[N]	340
Taper bearings output axial load	[N]	480

#### Accessories

Hollow output shaft	AC 25
---------------------	-------

#### Electric motor coupling

Size		63 A4
Poles n.		4
Power	[kW]	0.13

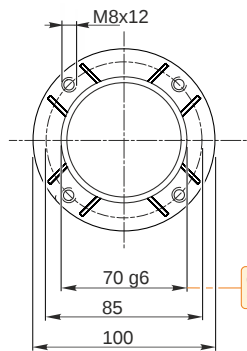
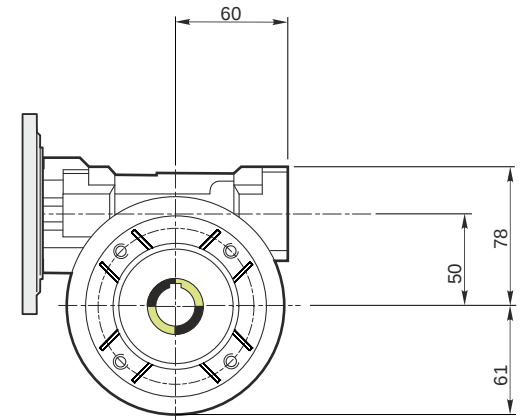
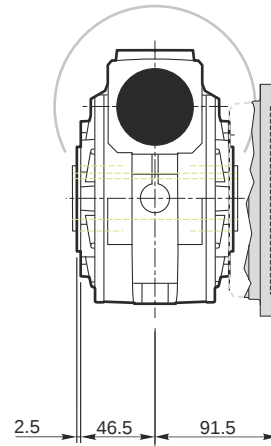
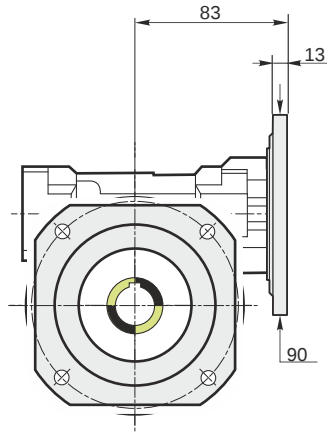

Hollow output shaft

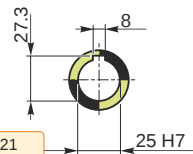

69.99  
69.971

25.021  
25.000

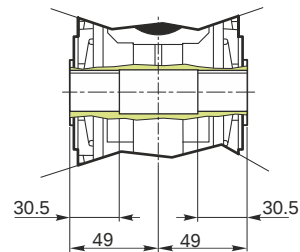

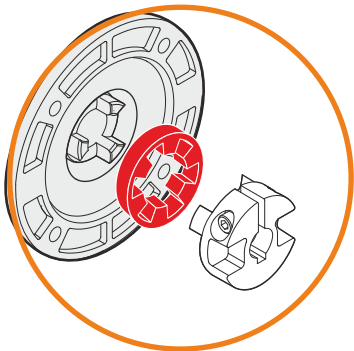
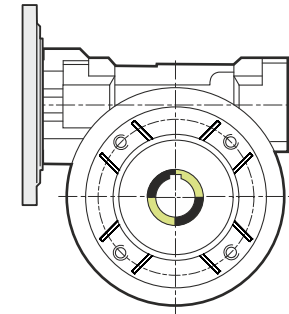
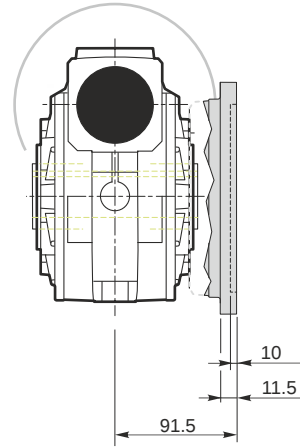
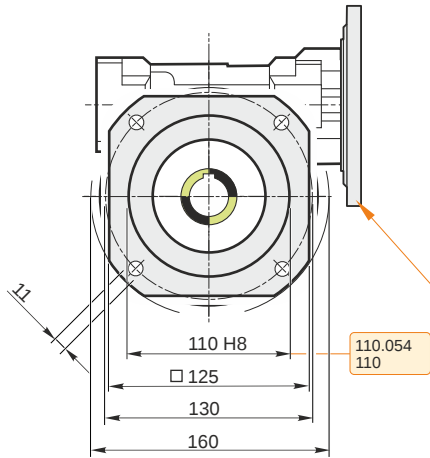

This gear unit is provided with an elastic coupling motor fitting

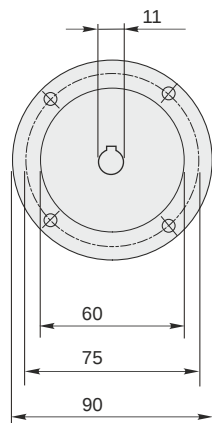

### Mounting positions

B3

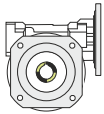

B6

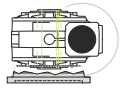

B7

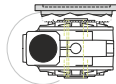

B8

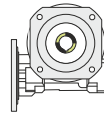

V5

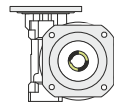

V6

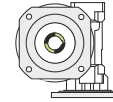

0.13



← Oil quantity [litres]

Lubricant type: Long life synthetic oil ISO VG320

### Direction of rotation

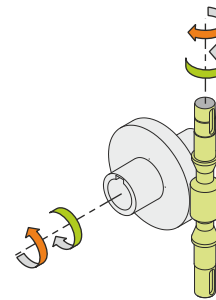
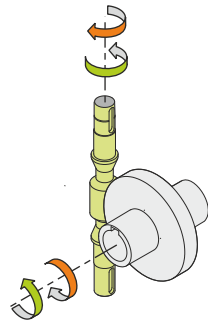
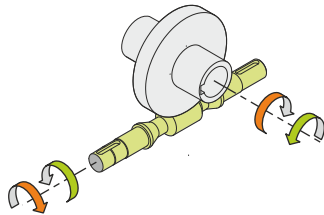
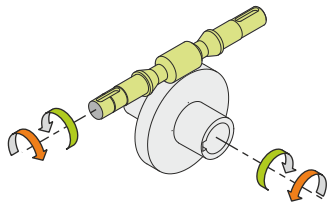

### Weight

Gear unit [kg] 3.8

### Gearing data

Axial module	2.5
Number of starts	2
Lead angle	11° 18'
Pressure angle	20°

### Backdriving

Variable static self-locking  
Quick back-driving in case of vibrations  
Dynamic back-driving